

F R E E M A N

7000 Placid, #101
Las Vegas, NV 89119
Ph: 702-407-4696 • Fax: 702-263-9260
FreemanLasVegasES@freemanco.com

NAME OF SHOW:	NAB Show April 20-23, 2009 / Las Vegas Convention Center	RTNDA April 20-22, 2009 / Las Vegas Hilton
COMPANY NAME:	BOOTH #:	
CONTACT NAME:	PHONE #:	
E-MAIL ADDRESS:		

For Assistance, please call 702-407-4696 to speak with one of our experts.



The mission of the Nature Conservancy is to preserve the plants, animals and natural communities that represent the diversity of life on Earth by protecting the lands and water they need to survive.

- Yes!** I would like to make a \$1.00 Voluntary Gift, to be matched by Freeman and Show Management for the Nature Conservancy.

Your \$1.00 Voluntary Gift becomes \$3.00 donated to the Nature Conservancy.

(You need to check the box located on the *Method of Payment* form or submit this form for the contribution to be applied).

For information on how your voluntary gift and matching contribution from Freeman and Show Management will be used, please visit the Nature Conservancy website at www.nature.org.

FREEMAN

7000 Placid, #101
 Las Vegas, NV 89119
 Ph: 702-407-4696 • Fax: 702-263-9260
 FreemanLasVegasES@freemanco.com



**ORDER
 DEADLINE DATE
 MARCH 6, 2009**

INCLUDE THE FREEMAN METHOD OF PAYMENT FORM WITH YOUR ORDER

NAB Show		RTNDA	
NAME OF SHOW: April 20-23, 2009 / Las Vegas Convention Center		April 20-22, 2009 / Las Vegas Hilton	
COMPANY NAME: _____		BOOTH#: _____	
ADDRESS: _____		BOOTH SIZE X	
CITY/STATE/ZIP: _____		CUSTOMER # _____	
PHONE #: _____	EXT.: _____	FAX #: _____	
SIGNATURE: _____		PRINT NAME: _____	
CONTACT'S E-MAIL _____			
E-MAIL FOR INVOICE _____		<input type="checkbox"/> CHECK IF YOU ARE A NEW FREEMAN CUSTOMER	

Invoices will be sent by e-mail, please provide e-mail address of the person who reconciles your invoices if different than above.

METHOD OF PAYMENT

BY SUBMITTING THIS FORM OR ORDERING MATERIALS OR SERVICES FROM FREEMAN, YOU AGREE TO BE BOUND BY ALL TERMS & CONDITIONS INCLUDED IN YOUR SERVICE MANUAL.

- | | |
|---|---|
| <p><input type="checkbox"/> COMPANY CHECK
 Please make check payable to: Freeman. Checks must be in U.S. funds drawn on a U.S. or Canadian bank. ("U.S. FUNDS" MUST BE PRE-PRINTED on Canadian checks.)
 Please reference (196579) on your remittance.</p> <p><input type="checkbox"/> CREDIT CARD
 For your convenience, we will use this authorization to charge your credit card account for your advance orders, and any additional amounts incurred as a result of show site orders placed by your representative. These charges may include all Freeman companies, or any charges which Freeman may be obligated to pay on behalf of Exhibitor, including without limitation, any shipping charges. Please complete the information requested below:</p> | <p><input type="checkbox"/> BANK TRANSFER
 Bank Transfer to Bank of America, N.A.; Dallas, TX
 <i>Wire Transfer</i>
 ABA#: 026009593 ACCT #1252039192 Freeman
 <i>International Wire Transfer</i>
 Swift Code: BOFAUS3N ACCT #1252039192 Freeman
 <i>ACH Direct Deposit</i>
 ABA# 111000012 ACCT #1252039192 Freeman
 Please reference Name of Show & Booth Number so we can properly credit your account.
 Note: Customers are responsible for any bank processing fees.</p> <p>INVOICES
 Exhibitor invoices for Freeman services will be available on the day the show opens. Your Method of Payment on file will be used to settle outstanding balances the day the show opens. Please visit the Freeman Service Center any time to review your charges and pick up a copy of your invoice(s).</p> |
|---|---|

AMERICAN EXPRESS DISCOVER MASTERCARD VISA DINERS CLUB CARTE BLANCHE

Account No.: _____ Exp. Date: _____
 Personal Credit Card Company Credit Card

Cardholder Name (Print): _____ Signature: _____

Cardholder Billing Address: _____

City/State/Zip: _____

ENTER TOTALS HERE

FURNISHINGS & ACCESSORIES	CARPET	CLEANING/ SHAMPOOING	PORTER SERVICE	RENTAL EXHIBITS & ACCESSORIES	INSTALLATION LABOR	DISMANTLE LABOR	MATERIAL HANDLING
RIGGING INSTALLATION	RIGGING DISMANTLE	HANGING SIGNS	SIGNS	UTILITIES	EXHIBIT TRANSPORTATION	NATURE CONSERVANCY	GRAND TOTAL
						\$1.00	

****Yes! I would like to make a \$1.00 voluntary gift, to be matched by Freeman and Show Management for The Nature Conservancy. You will need to check the box for the contribution to be applied.**

- Remember to order in advance to save time and money. You may place your order by phone, fax, mail, or use our online ordering service at: www.myfreemanonline.com.
- Orders received without payment or after the discount price deadline date will be charged at the standard price.
- Copies of invoices may be picked up from the Service Desk prior to show closing.
- If you have questions or need assistance with any items not listed, please call and ask for your Exhibitor Sales Representative.

TELL US WHAT YOU THINK

Freeman is committed to providing great customer service. To help us serve you more effectively in the future, please visit the URL address below upon the completion of your show to provide feedback. Your input will provide the insight needed to ensure that our customer service is in line with your expectations.

<http://totalshow.custominsight.com/?196579>

(196579)

FREEMAN method of payment

F R E E M A N

7000 Placid, #101
Las Vegas, NV 89119
Ph: 702-407-4696 • Fax: 702-263-9260
FreemanLasVegasES@freemanco.com

ENVIRONMENTAL EXHIBITS

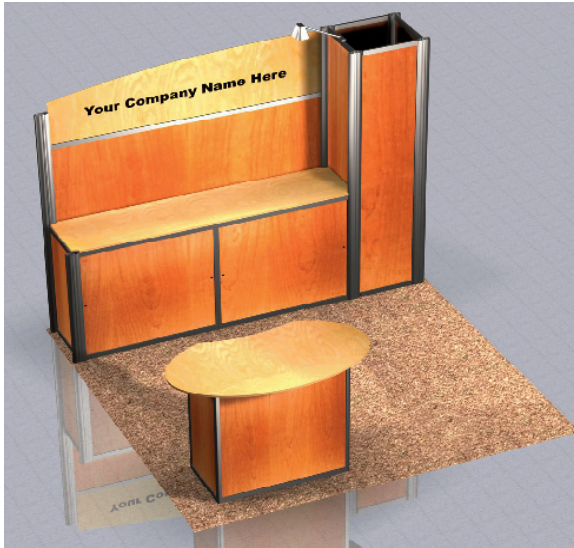

ENVIRONMENTAL 1A
With Storage Cabinet
Pictured Above with Cherry
and Ash Panels

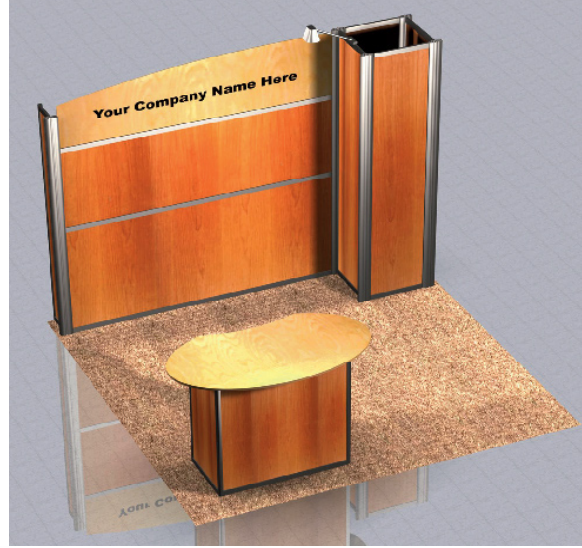

ENVIRONMENTAL 1B
With out Storage Cabinet
Pictured Above with Cherry
and Ash Panels



ENVIRONMENTAL 2A
With Storage Cabinet
Pictured Above
with Ash Panels



ENVIRONMENTAL 2B
With out Storage Cabinet
Pictured Above
with Cherry Panels

INCLUDE THE FREEMAN METHOD OF
 PAYMENT FORM WITH YOUR ORDER

NAB Show		RTNDA	
NAME OF SHOW:	April 20-23, 2009 / Las Vegas Convention Center	April 20-22, 2009 / Las Vegas Hilton	
COMPANY NAME:		BOOTH #:	
CONTACT NAME:		PHONE #:	
E-MAIL ADDRESS:			

For Assistance, please call 702-407-4696 to speak with one of our experts.

For fast, easy ordering, go to www.myfreemanonline.com

Let Freeman provide an Environmentally Friendly Exhibit Package for your use at the Natural Products Expo.

Packages cannot be ordered at showsite. Only advance orders will be accepted.

All exhibits Include:

- Installation & Dismantle of Exhibit
- Material Handling of Exhibit
- ECO Carpet with Nightly Vacuuming
- 1 Light Fixture (per 10' unit)

Note: Electrical service must be ordered separately
 (Choose Your Package)

The exhibit packages are FSC Certified Hardwood Plywood Panels. Our sustainably harvested hardwood MDF-core plywood panels are Forest Stewardship Council Certified, formaldehyde-free, and earn one point for LEED's EQ Credit 4.4 for low emitting materials. Aluminum extrusions are made of 85% recycled content and are 100% recyclable.

PACKAGES

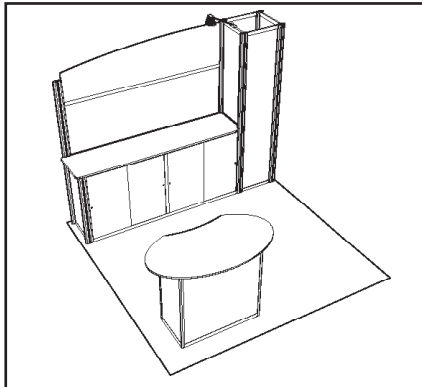
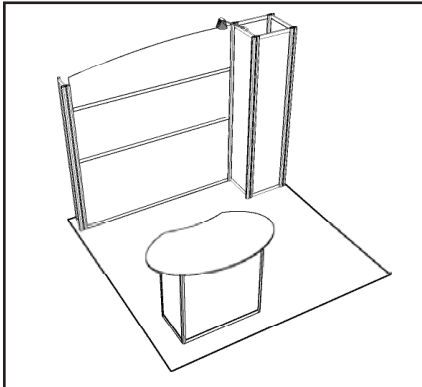

ENVIRONMENTAL 1A	ENVIRONMENTAL 1B
<input type="checkbox"/> OPTION 1A - WITH STORAGE CABINET Price per Package: \$3,350.45 	<input type="checkbox"/> OPTION 1B - WITHOUT STORAGE CABINET Price per Package: \$2,758.40 

- Electrical Service is not included in the price for your rental exhibit. For electrical service, please refer to the Electrical Order Form.

ENVIRONMENTALLY FRIENDLY CARPET

Our Environmentally Friendly Carpet and nightly vacuuming are included in the price of your Rental Exhibit. The environmental friendly carpet fiber contains 25% recycled content and is 100% recyclable back into carpet fiber (again and again). The following colors are available.

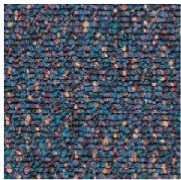
(Choose color choice)

<input type="checkbox"/> Desert	<input type="checkbox"/> Thunder	<input type="checkbox"/> Camouflage
		

Check here if you would like to have an Exhibitor Sales Specialist contact you regarding 100% recyclable graphics using UV printing systems, or if you need further assistance in creating an unique exhibit that meets your specific needs!

(196579)

HEADER IDENTIFICATION SIGN

Circle the font style for your header identification sign, and then indicate your color preference.

CLARENDON MEDIUM	ENVIRO
EUROSTILE BOLD	HELVETICA BOLD
TIMES NEW ROMAN	

Indicate which color lettering you would like. We have a wide variety of standard colors available:

Letter color desired: _____

Indicate exactly how you want your company name to appear:

Custom Logo Header - Please check to have an Exhibitor Sales Specialist contact you regarding pricing.

Subtotal	+ 7.75% Tax	= \$	Total Cost
----------	-------------	------	------------

FREEMAN environmentally friendly exhibit packages

**INCLUDE THE FREEMAN METHOD OF
 PAYMENT FORM WITH YOUR ORDER**

NAB Show **RTNDA**
 NAME OF SHOW: April 20-23, 2009 / Las Vegas Convention Center April 20-22, 2009 / Las Vegas Hilton

COMPANY NAME: _____ BOOTH #: _____

CONTACT NAME: _____ PHONE #: _____

E-MAIL ADDRESS: _____

For Assistance, please call 702-407-4696 to speak with one of our experts.

For fast, easy ordering, go to www.myfreemanonline.com

Let Freeman provide an Environmentally Friendly Exhibit Package for your use at the Natural Products Expo.

Packages cannot be ordered at showsite. Only advance orders will be accepted.

All exhibits Include:

- Installation & Dismantle of Exhibit
- Material Handling of Exhibit
- ECO Carpet with Nightly Vacuuming
- 1 Light Fixture (per 10' unit)

Note: Electrical service must be ordered separately
 (Choose Your Package)

The exhibit packages are FSC Certified Hardwood Plywood Panels. Our sustainably harvested hardwood MDF-core plywood panels are Forest Stewardship Council Certified, formaldehyde-free, and earn one point for LEED's EQ Credit 4.4 for low emitting materials. Aluminum extrusions are made of 85% recycled content and are 100% recyclable.

PACKAGES

ENVIRONMENTAL 2A

OPTION 2A - WITH STORAGE CABINET

Price per Package:
 \$3,493.45

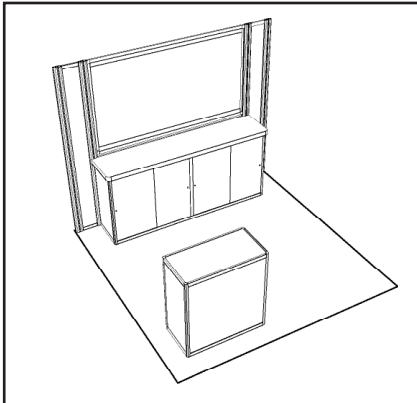

ENVIRONMENTAL 2B

OPTION 2B - WITHOUT STORAGE CABINET

Price per Package:
 \$2,900.60

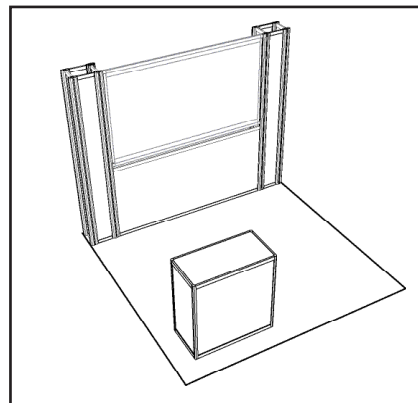

- Electrical Service is not included in the price for your rental exhibit. For electrical service, please refer to the Electrical Order Form.

**FSC CERTIFIED FORMALDEHYDE-FREE
 HARDWOOD PLYWOOD PANELS**

(Choose Your Panels)

- Cherry** **Ash**

ENVIRONMENTALLY FRIENDLY CARPET

Our Environmentally Friendly Carpet and nightly vacuuming are included in the price of your Rental Exhibit. The environmental friendly carpet fiber contains 25% recycled content and is 100% recyclable back into carpet fiber (again and again).

The following colors are available.

(Choose color choice)

- Desert** **Thunder** **Camouflage**



(196379)

WATER-BASED ECO FRIENDLY BANNER

Send us your graphic image you would like produced on your 93" x 52 1/4" banner. Please refer to the Artwork Guidelines on the next page for complete instructions on submitting your graphic files. When providing artwork, please be aware that there will be a pocket seam 5" from the top of the banner and 5" from the bottom of the banner.

- Check here if you would like to have an Exhibitor Sales Specialist contact you regarding 100% recyclable graphics using UV printing systems, or if you need further assistance in creating an unique exhibit that meets your specific needs!

**Orders must be received by the deadline date.
 These packages will not be available at show site.**

Subtotal	+	7.75% Tax	= \$	Total Cost
-----------------	---	------------------	------	-------------------

FREEMAN environmentally friendly exhibit packages

CUSTOMER GUIDELINES FOR SUBMITTING GRAPHICS ARTWORK

Our desire is to provide you with the best possible quality graphics for your event or exhibit. You can help us in that effort by providing digital art files using the following guidelines. If you are sending us completed, print-ready files, please pass the following information on to your graphics designer. Two overall considerations for submitting acceptable artwork involves proper resolution or size of the file to avoid poor quality images, and proper color matching information and proofs to ensure accurate color reproduction.

PLEASE PROVIDE THE FOLLOWING WHEN SUBMITTING ART

Minimum requirements for original artwork, such as logos, when Freeman is providing design and layout:

- 300 dpi resolution at a size of 8 x 10 inches (higher resolution files will result in improved final product)

Minimum requirements for final artwork that Freeman will reproduce exactly as provided:

- 100 dpi resolution at full size of actual finished product

Minimum requirements for both:

- All related PMS and/or CMYK color codes (if submitting CMYK values, please supply accurate color swatches)
- Accurate color proof print of artwork
- Contact name, phone number and e-mail address of art creator if applicable
- If submitting a "vector" file, include all fonts, or convert fonts to outlines or paths

ACCEPTABLE FILE SOFTWARE FORMATS

We are capable of working with both PC and MAC based software, and can accept art created with the following software programs (listed in order of preference):

- ADOBE—Illustrator, InDesign, and Photoshop
- COREL DRAW
- QUARK XPRESS

Files should always be saved in their native format.

ACCEPTABLE FILE TYPES

Files that Freeman **can use** in order of preference, include:

- EPS and AI (especially when submitting logos)
- TIF (especially when submitting photos)
- JPG (provided resolution is high enough for photo images; not recommended for logos)

File types that Freeman **cannot use** to reproduce high quality graphics include:

- GIF files
- Microsoft Office software files such as Word (.doc), or PowerPoint (.ppt) file types
- Self-extracting files, such as EXE or SEA files

WAYS TO SEND ARTWORK

- Artwork files that are of acceptable resolution as listed above will typically be too large to send via e-mail. Files should be sent via overnight delivery on either a CD-ROM or a DVD. A printed hard proof needs to accompany the files.
- Files may also be posted to Freeman's FTP site. You may get the password and other needed information from your Freeman service representative in order to post files. However, a hard copy proof and backup must be sent via overnight delivery in addition to posting the electronic files.

Please visit us at: www.freemanco.com

INCLUDE THE FREEMAN METHOD OF
PAYMENT FORM WITH YOUR ORDER

NAB Show **RTNDA**
NAME OF SHOW: April 20-23, 2009 / Las Vegas Convention Center April 20-22, 2009 / Las Vegas Hilton

COMPANY NAME: BOOTH #:

CONTACT NAME: PHONE #:

E-MAIL ADDRESS:

For Assistance, please call 702-407-4696 to speak with one of our experts.

For fast, easy ordering, go to www.myfreemanonline.com

Let Freeman provide a Recyclable Exhibit Package for your use at the Natural Products Expo.

SAVE TIME AND THE ENVIRONMENT WITH A RECYCLABLE BOOTH PACKAGE!
Our standard package below is constructed using our modular rental system with vertically corrugated panels and shelves made of 63% recycled content and is 100% recyclable. Aluminum extrusions are made of 85% recycled content and are 100% recyclable. Carpet is 100% recyclable into drainage pipe.

Packages cannot be ordered at showsite. Only advance orders will be accepted.

RECYCLABLE EXHIBIT PACKAGE

Items included:

- White or Black Recyclable Panels*
- 3-Recyclable Shelves per 10'
- 2 Arm Lights (electricity not included)
- Recyclable Header Identification Sign
- Recyclable Classic Carpet w/Nightly Vacuuming**
- Delivery, set-up and teardown of rental package

Items not included:

- Electrical
- Special graphics
- Furniture
- Unpacking/repacking product
- Material handling

10' x 10' Recyclable Unit
Price per Unit:
\$2,106.25

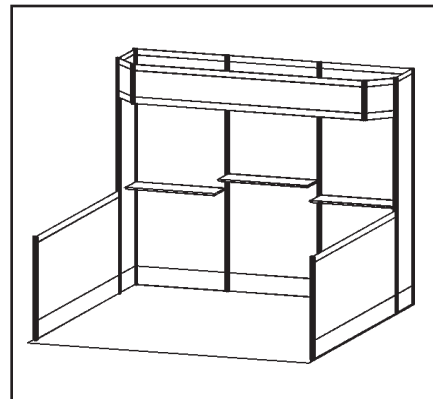

• Orders cancelled after production begins are subject to a 100% Cancellation Charge.

RECYCLABLE PANELS

*Check color choice

- White Black

RECYCLABLE CLASSIC CARPET

Our Classic Carpet and nightly vacuuming are included in the price of your Rental Exhibit. The following colors are available.

**Check color choice

- Tuxedo Green Teal
 Blue Black Red
 Gray Burgundy Plum

You may upgrade your carpet to one of our 15 designer colors in our PRESTIGE carpet line. Now available in **28 oz.** and **40 oz.** weight. Refer to our enclosed Carpet order form for color selections and pricing.

LIGHTING

Rental Exhibit includes 2 Arm Lights (per 10' unit).
Note: Electrical power must be ordered using the electrical order form included in your service manual.

- Electrical power and labor to install lights must be ordered separately
- Custom graphics must be ordered separately

(1965/9)

HEADER IDENTIFICATION SIGN

Circle the font style for your header identification sign, and then indicate your color preference.

- CLARENDON MEDIUM ENVIRO
EUROSTILE BOLD HELVETICA BOLD
TIMES NEW ROMAN

Indicate which color lettering you would like. We have a wide variety of standard colors available:

Letter color desired: _____

Indicate exactly how you want your company name to appear:

CONTACT FOR PRICING

Please check any of the following boxes to have an Exhibitor Sales Specialist contact you for pricing:

- Upgrade Carpet
- Custom Logo Header
- Creating a Custom Exhibit

Sub-Total _____ + Tax (7.75%) _____ = TOTAL _____

FREEMAN

7000 Placid, #101
 Las Vegas, NV 89119
 Ph: 702-407-4696 • Fax: 702-263-9260
 FreemanLasVegasES@freemanco.com



ORDER
 DEADLINE DATE
MARCH 6, 2009

**INCLUDE THE FREEMAN METHOD OF
 PAYMENT FORM WITH YOUR ORDER**

NAB Show		RTNDA	
NAME OF SHOW:	April 20-23, 2009 / Las Vegas Convention Center	April 20-22, 2009 / Las Vegas Hilton	
COMPANY NAME:			BOOTH #:
CONTACT NAME:			PHONE #:
E-MAIL ADDRESS:			

For Assistance, please call 702-407-4696 to speak with one of our experts.

For fast, easy ordering, go to www.myfreemanonline.com

ADVANCE ORDERS ONLY!

Freeman is pleased to provide Dotcom II, an environmentally friendly carpet for you to order for your booth space. Dotcom II is a Shaw Contract Group carpet and the fiber contains 100% Eco Solution Q premium branded SD nylon. Eco Solution Q from Shaw Fibers contains a minimum of 25% recycled content, comprised of both post industrial and post consumer material, and it is fully recyclable back into carpet fiber.

Please choose your carpet color from the choices listed below (Please Check Box or Circle):

- Price includes visqueen covering, delivery, installation, carpet tape, and carpet removal.
- No MATERIAL HANDLING charges on carpet ordered from Freeman!
- Rental - Price per square foot (100 sq.ft. minimum).



CAMOUFLAGE

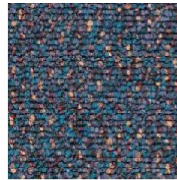

THUNDER



DESERT

Price per
Sq. Ft.

Booth Size: _____ x _____ = _____ sq.ft. @ \$ 3.60 = \$ _____

- Check here if your booth is 400 sq. ft. or more and your electrical/phone lines are to be installed before carpet installation.

CARPET PADDING AND VISQUEEN

- Price includes delivery, installation, and removal.
- No MATERIAL HANDLING charges on carpet padding ordered from Freeman!

Price per
Sq. Ft.

Carpet Padding - 1/2" (90 - 700 sq.ft.) Booth Size: _____ x _____ = _____ sq.ft. @ \$.65 = \$ _____

Carpet Padding - 1/2" (Over 700 sq. ft.) Booth Size: _____ x _____ = _____ sq.ft. @ \$.60 = \$ _____

Visqueen Covering (per sq. ft.) Booth Size: _____ x _____ = _____ sq.ft. @ \$.25 = \$ _____

REMOVAL OF VISQUEEN

Carpets rented and/or installed by Freeman include removal of visqueen prior to show opening. Display Labor charges will apply for removal of visqueen on carpets not installed or rented from Freeman.

TOTAL CARPET COST		
Sub-Total _____	+ Tax (7.75%) _____	= TOTAL _____